

This product is intended for installation only by expert users. Please consult with a qualified technician for installation. Improper installation may result in damage to your equipment. EK Water Blocks assumes no liability whatsoever, expressed or implied, for the use of these products, nor their installation. The following instructions are subject to change without notice. Please visit our web site at [www.ekwb.com](http://www.ekwb.com) for updates. Before installation of this product please read important notice, disclosure and warranty conditions printed on the back of the box.

Before you start using this product please follow these basic guidelines:

1. Please carefully read the manual before through before beginning with the installation process!
2. Please remove your motherboard from the computer to assure safest mounting process in order to prevent any possible damages to your CPU and/or motherboard's circuit board (PCB).
3. The EK-HFB, EK-HDC and EK-ACF type fittings require only a small amount of force to screw them firmly in place as the liquid seal is ensured by the rubber o-ring gaskets.
4. The use of corrosion inhibiting coolants is always recommended for any liquid cooling system.

## STEP 1: GENERAL INFORMATION ON PRODUCT

Congratulations on your purchase of EK-Supremacy MX CPU water block. This water block is pre-assembled for use with modern Intel desktop socket type motherboards. By default this water block supports the following CPU sockets:

- Intel socket LGA-115x and LGA-2011(-3)

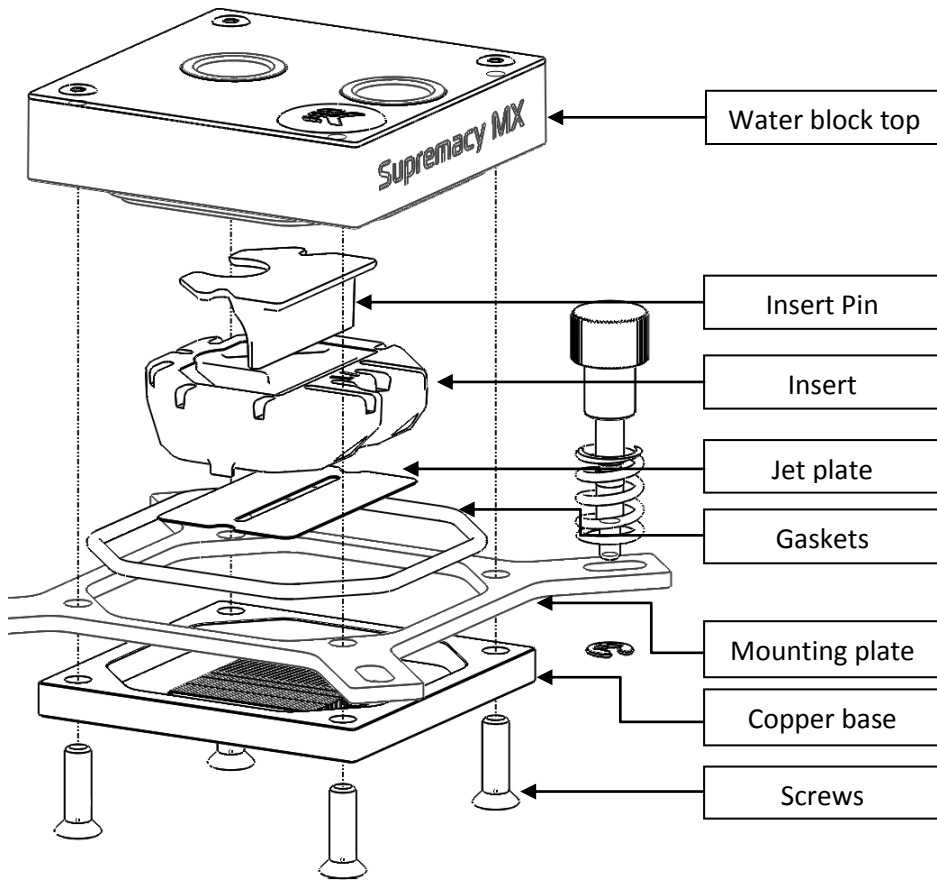

**Caution:**  
Narrow server type LGA-2011 is not supported by default – a **Mounting plate Supremacy LGA-2011 Narrow ILM** (EAN: 3830046990600) is mandatory to install this water block on narrow server type LGA-2011 motherboards.

## STEP 2: TABLE OF CONTENT

The following items are enclosed with each EK-Supremacy MX water block:

- EK-Supremacy MX universal CPU water block /w pre-installed Insert I2 and Jet J1 (0.25mm) (all around great performer)
  - o Pre-installed mounting mechanism
- EK-Supremacy MX Backplate
  - o Backplate BAS gasket
  - o Backplate for Intel LGA-115x socket motherboards
- Torx key T20
- EK-TIM Ectotherm 1g thermal grease

**Note:** To disassemble pre-installed mounting mechanism please release the circlip under each mounting screw.

## STEP 3 (optional): POSSIBLE UPGRADE PATH TO EVO STANDARD

EK-Supremacy MX uses the same Insert and Jet plate system as EK-Supremacy EVO, however the additional parts must be purchased separately. EK-Supremacy MX can also be upgrade to full EK-Supremacy EVO standard with the following parts:

- EK-Supremacy (EVO) Backplate
- EK-Supremacy EVO *PreciseMount* mounting mechanism
- EK-Supremacy EVO parts
  - o Insert I1
  - o Jet J2
  - o Jet J3
  - o Copper cold plate (base)
  - o AMD Mounting Plate

These parts can be purchased through EK Webshop or Partner Reseller Network:



## STEP 4 (optional): INSTALLING ALTERNATIVE MOUNTING PLATE AND REPLACING JET PLATE / INSERT PROCEDURE

- 1) Place water block on an even surface and remove four M4x16 DIN7991 screws attaching the top to the copper base using the 2.5mm Allen key (not enclosed).
- 2) Replacing mounting plate:**
  - 2.1) Replace the Intel mounting plate with alternative one. You will feel the mounting plate locking into the position when placed correctly on to the top.
  - 2.2) Reseat the larger o-ring gasket (57x2 mm) into the gap between the mounting plate and water block top.
- 3) Replacing jet plate (OPTIONAL):**
  - 3.1) Remove the default Jet J1 (0.25mm thick) and replace it with Jet J2 (0.3mm) or Jet J3 (0.1mm), depending on your CPU platform. You will feel the jet plate locking into the position when placed correctly to the water block Insert.
- 4) Replacing insert (OPTIONAL):**
  - 4.1) Remove the default Insert I2 and replace it with Insert I1, depending on your CPU platform. It is mandatory to install the Insert Pin and Insert in correct way, there is only one way to install it. You will feel the Insert assembly locking into the position when placed correctly to the water block.
- 5) Carefully place copper base to waterblock top assembly, make sure gaskets stay in place! **Beware of copper base orientation!**
- 6) Repeat step #5 if necessary. Screw in all four (4) M4x16 DIN7991 screws using the 2.5mm Allen (hex) key.

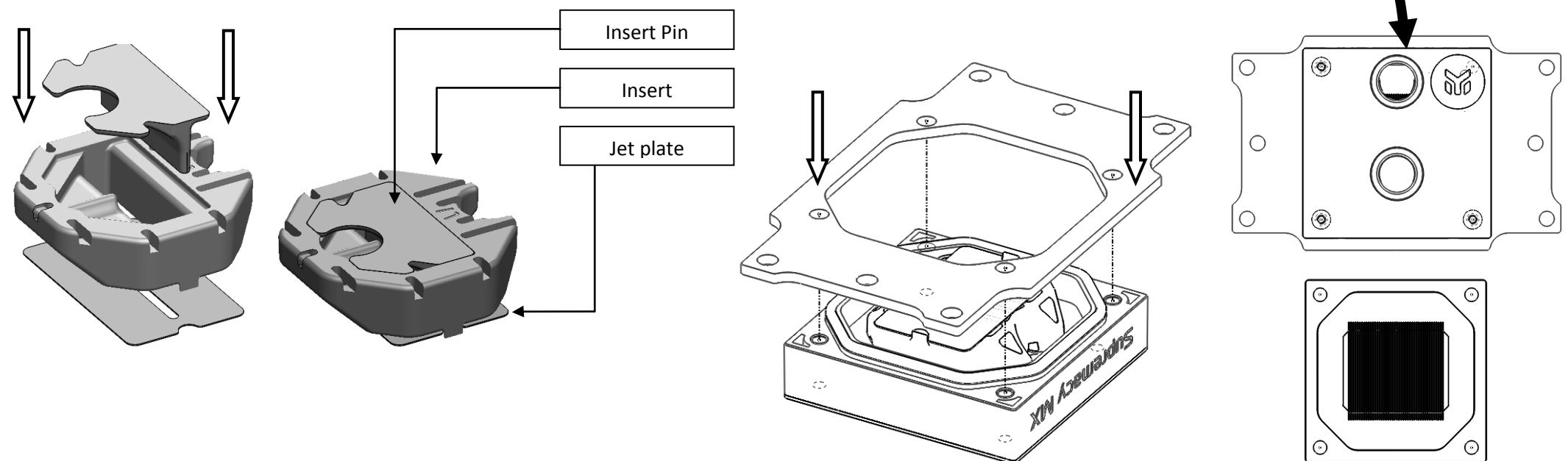

## STEP 5: INSTALLING THE WATER BLOCK:

### STEP 5a: Intel LGA-115x motherboards:

Installing this water block on LGA-115x system requires two pre-steps – removing of the original Backplate and replacing it with EK-Supremacy MX Backplate.

- 1) Place motherboard on an even surface with front side facing up.
- 2) Using enclosed Torx key T20 remove the three UNC 6-32 screws securing the socket latch mechanism (ILM) and original backplate (BP) to the motherboard. See sketches below for part identification:

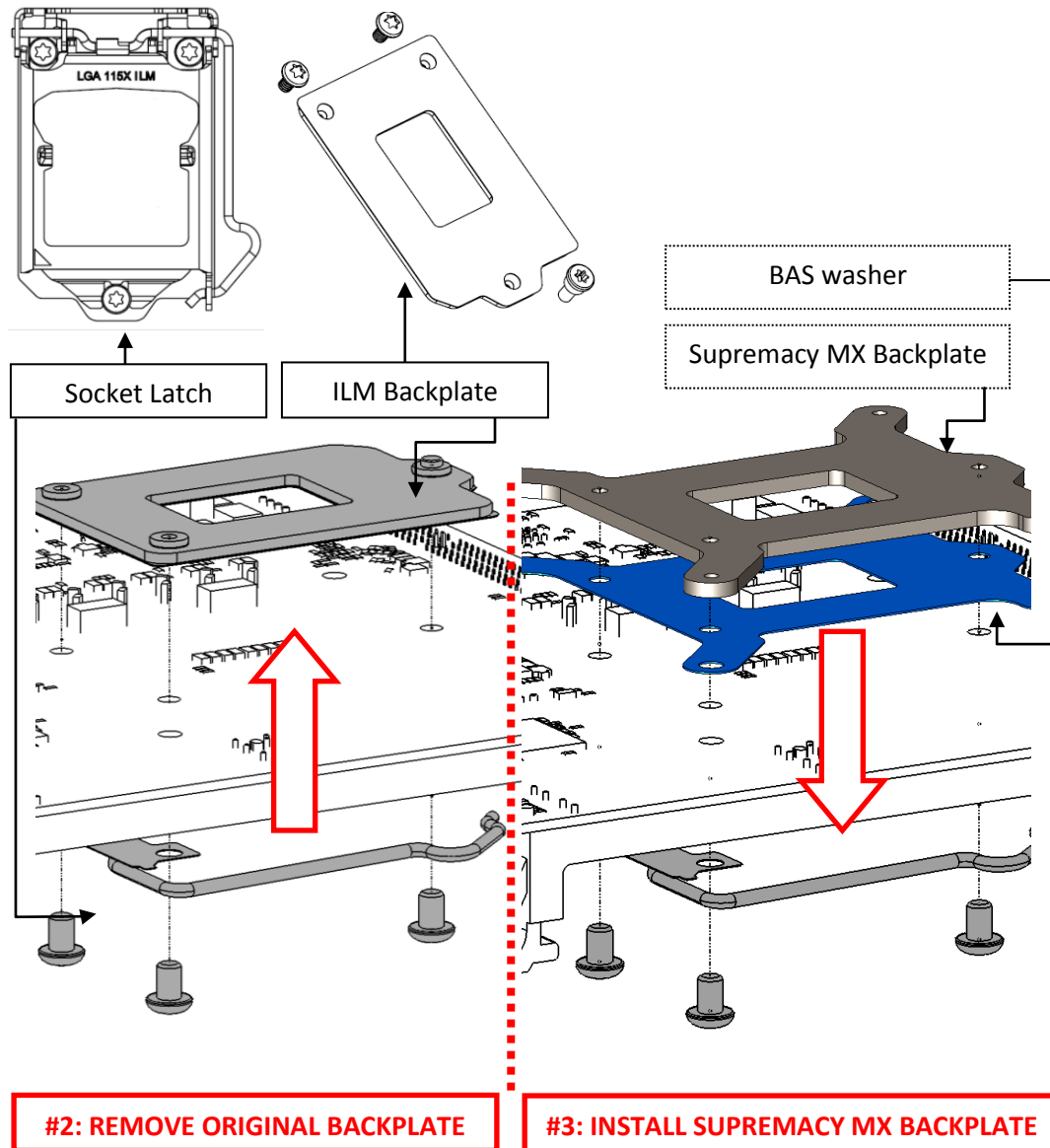

3) **Replace the original ILM backplate** with the enclosed EK-Supremacy MX Backplate and BAS washer and then secure it using three original UNC 6-32 screws.

- 4) Re-tighten the screws using enclosed Torx key T20.
- 5) Install CPU and **apply TIM** (thermal grease) as shown in STEP 6
- 6) Align water block with pre-installed mounting mechanism above the LGA-2011(-3) motherboard with pre-installed CPU.
- 7) Tighten the screws with your thumbs until you reach the end of the thread, preferably by tightening two thumb screws at a time in the cross pattern. Do not use any tools (such as pliers) during this process!

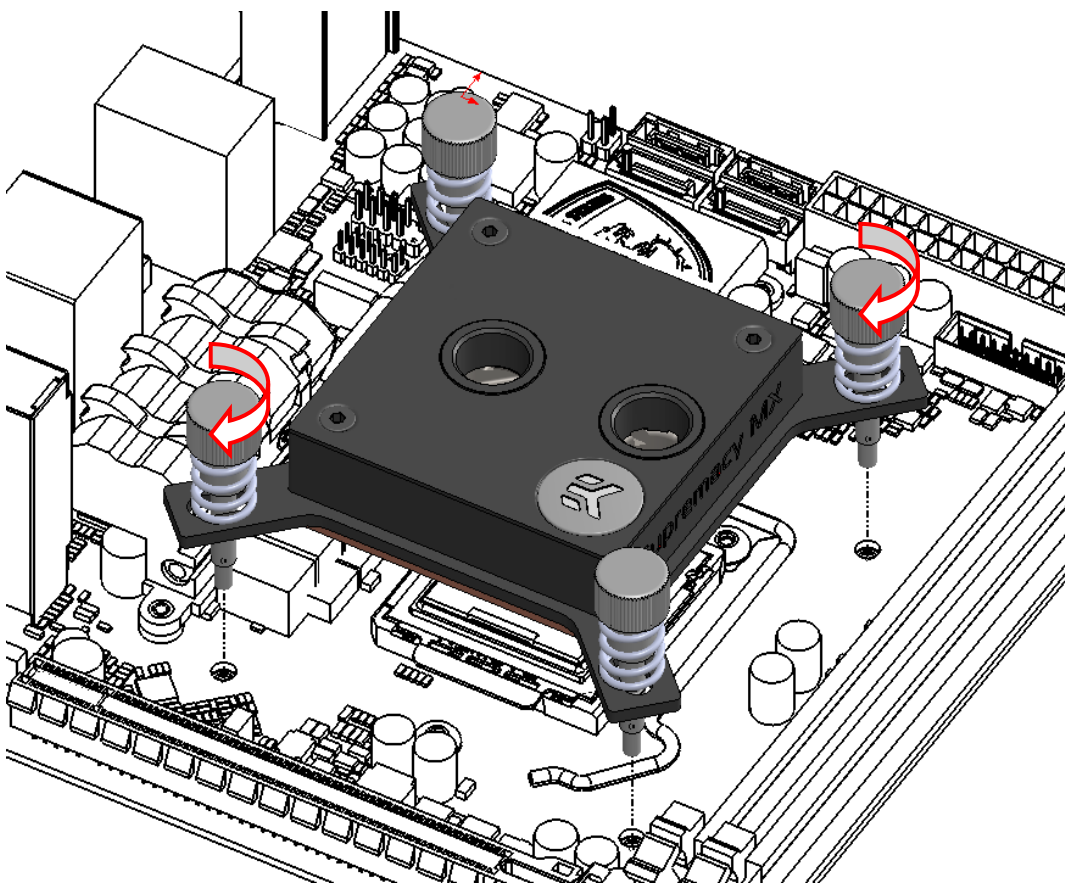

### STEP 5b: Intel LGA-2011 socket motherboard:

- 1) On majority of motherboards the EK-Supremacy MX can be successfully installed with motherboard already being pre-fitted to the computer chassis. Still, it is best practice to place a motherboard on an even surface with front side facing up.
- 2) Store away the EK-Supremacy MX Backplate as it is not needed with LGA-2011 series CPUs.
- 3) Install CPU and **apply TIM** (thermal grease) as shown in STEP 6
- 4) Align water block with pre-installed mounting mechanism above the LGA-2011(-3) motherboard with pre-installed CPU.
- 5) Tighten the screws with your thumbs until you reach the end of the thread, preferably by tightening two thumb screws at a time in the cross pattern. Do not use any tools (such as pliers) during this process!

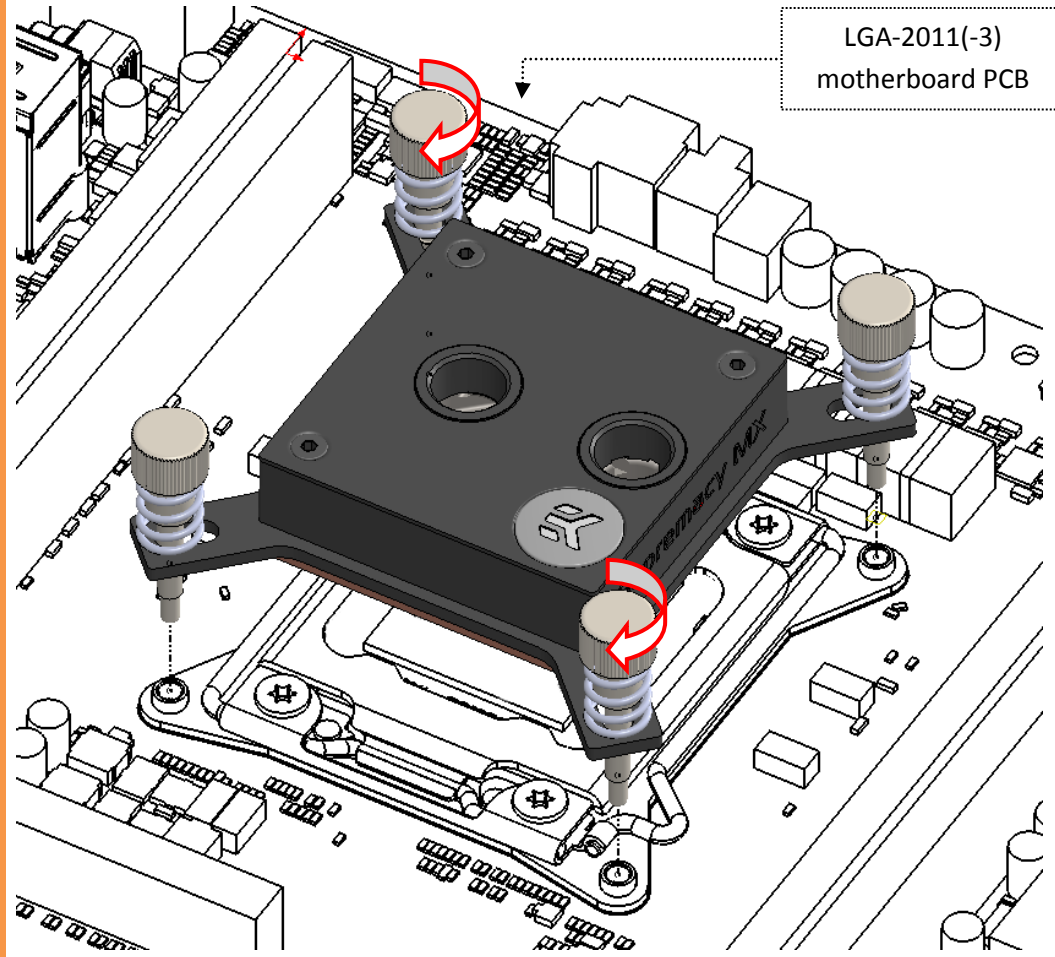

## STEP 6: PREPARING CPU AND APPLYING THERMAL GREASE (TIM):

**Cleaning the CPU:** Wipe the CPU's contact surface (by using non-abrasive cloth or *Q-tip*, as shown on sample photo).

**Applying thermal compound:** EK recommends blob or line method of applying the enclosed EK-TIM Ectotherm™ thermal compound to the CPU heatspreader (IHS) - see sample photo on right. The quantity of about two-(LGA-115x) or three (LGA-2011) rice grains is just about right. There is no need to cover the whole IHS. Applying too much thermal grease will have negative impact on the cooling performance!

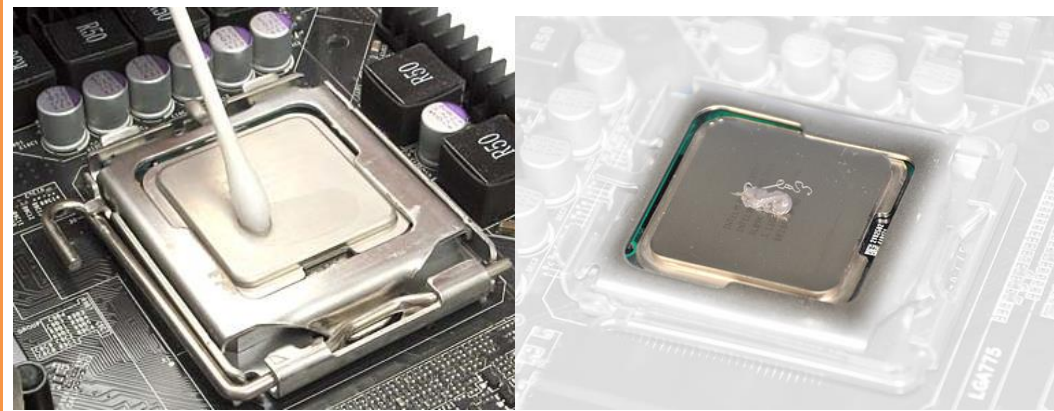

## STEP 7: CONNECTING THE WATER BLOCK TO THE COOLING LOOP:

Carefully identify the direction of the flow in your circuit. For the EK-Supremacy MX series water block to operate properly the G1/4 port nearest to the center of the water block **MUST BE USED AS THE INLET PORT**. EK recommends the use of EK-ACF Fittings. When using fittings other than EK-ACF series please use hose clamps or appropriate substitute to secure the tubing to the barb. The use of biocide containing and corrosion inhibiting coolant is always recommended for any liquid cooling system.

